



NEBA1701



NEBA1701 PART#N002



1D Barcode Scanner - Newland

The Newland Barcode is a 1D engine that provides flexibility to any kind of applications such as data collection and price checkers. Mostly used to open a browser upon scan or to open a page in an app. Glory Star provides a demo APK- STARTOOL to support your software integration to our tablet. The barcode is easily installed by users, providing an integrated solution and eliminating the need for external brackets or attachments.

Newland ID Barcode Scanner Specifications

Brand	Newland
Reader Type	1D barcode reader
Sensor model	NLS-EM1365-LD
Enclosure color	Black
Support OS	Android/ Windows/ Linux
Sensor	Linear Imager
Resolution	1500
Scan Rate	300 scans per second
Illumination & Aiming	LED (610nm ~ 640nm)
Reading Precision	≥ 4mil
Ideal Scan Distance	Code 39 (5mil): 65mm~175mm EAN-13 (13mil): 55mm~605mm
Supported Symbolologies	EAN-13, EAN-8, UPC-A, UPC-E,ISSN, ISBN, Codabar, Code 128, Code 93, ITF-6, ITF-14,Interleaved 2 of 5, Industrial 2 of 5, Standard 2 of 5, Matrix 2 of 5,GS1 Databar, Code 39, Code 11, MSI-Plessey, Plessey
Field of view	/
Beeper Output	YES
Ambient Light	0~100000 lux
Operating Temperature	-20°C ~ + 55°C
Humidity	5% - 95% (non-considering)
Voltage	5V
Barcode Working mode	USB virtual serial port mode, USB virtual keyboard mode
Product Weight	67g
Dimensions	57.85 x 47.29 x 47.15mm
Gift Box Weight	99g
Gift Box Dimensions	140 x 83 x 44mm
What's in the Box	1D barcode reader, 2 Screws

Barcode Model	Model	System platform
NEBA1701	GAD101	Android
NEBA1701 PART#N002	ALU100, ALU150, ALU210	Android
NEBA1701 PART#N002	ULT101, ULT156, ULT215	Windows

Barcode Scanning Angle

NEBA1701

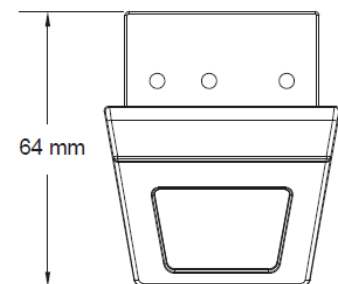
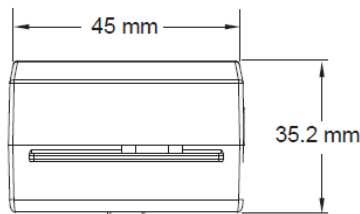
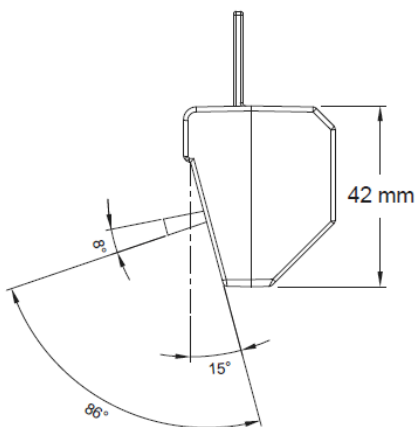

NEBA1701 PART#N002

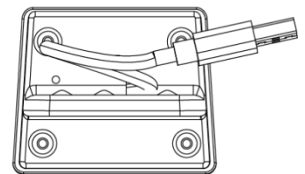
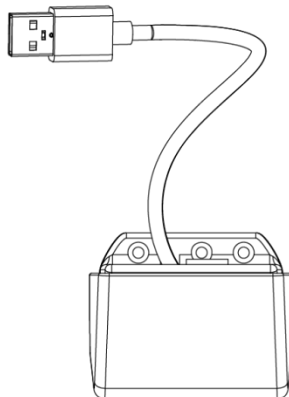
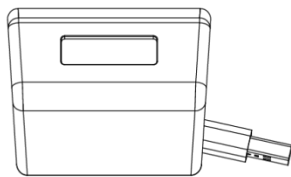
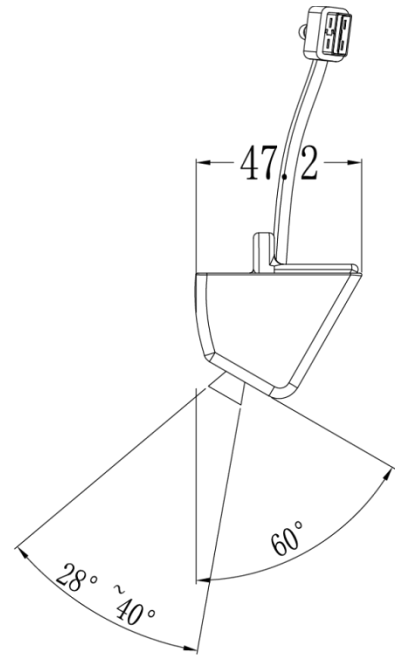
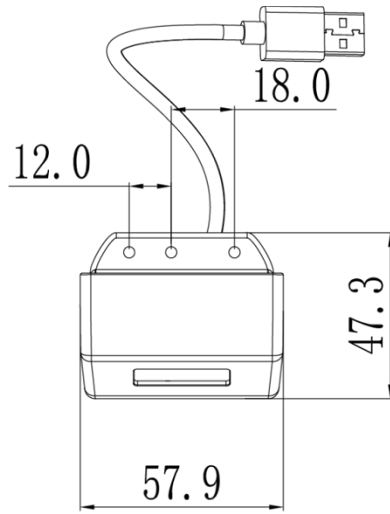
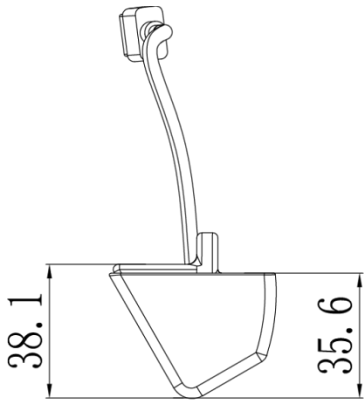

CONTACT US

United States	Hong Kong	ShenZhen
Representative Office 101 Hudson St., 21st Floor Jersey City, NJ 07302 USA	Flat D, 5/F, Excelsior Building, 364 Nathan Road, Kowloon, Hong Kong	Bldg 9, 4/F Zhong Yuntai Technology Industrial Park, Tangtou No.1 Road, Shiyuan Street, Baoan, ShenZhen, PRC
626 228 5927	852 23762803	86 755 2600 1808
sales@glorystargroup.com	sales@glorystargroup.com	sales@glorystargroup.com

To find out more about our extensive range of Glory Star solutions, go to www.glorystargroup.com, or call the office nearest you. For more information, please contact us at sales@glorystargroup.com. Glory Star reserves the right to change or update, without notice, any information contained herein; to change, without notice, the design, construction, materials, processing or specifications of any products; and to discontinue or limit production or distribution of any products. Glory Star, the Glory Star logo, STAR CONTROL and STAROS are either trademarks or registered trademarks of Glory Star Group Limited. All other trademarks are the property of their respective owners.