



NEB1702 - 2D Barcode Scanner

The Honeywell Barcode is a 1D and 2D engine that provides flexibility to any kind of applications such as data collection and price checkers. Mostly used to open a browser upon scan or to open a page in an app. Glory Star provides a Demo APK to support your software integration to our tablets, please go to our support page to download the demo APK. The barcode is easily installed by users, providing an integrated solution and eliminating the need for external brackets or attachments.

NEB1702 - 2D Barcode Scanner Specification

Brand	Honeywell
Support OS	Android 9.0
Barcode engine	N4680
Interface	USB Type C
Reader Type	1D/2D barcode reader
Sensor	Global shutter
Resolution	640 x 480
Ideal Scan Distance	EAN-13 (13mil): 60mm~290mm PDF417 (6.67mil): 55mm~135mm Code 39 (5mil): 55mm~165mm Data Matrix (10mil): 55mm~130mm QR Code (15mil): 45mm~175mm
Supported Symbologies	2D: Codablock A, Codablock F, PDF417, MicroPDF417, Aztec Code, Data Matrix, MaxiCode, QR Code, Chinese Sensible (Han Xin), Grid Matrix, Dot Code 1D: Codabar, Code 11, Code 128, Code 2 of 5, Code 39, Code 93 and 93i, EAN/JAN-13, EAN/JAN 8, IATA Code 2 of 5, Interleaved 2 of 5, Matrix 2 of 5, MSI, GS1 Databar, UPC-A, UPC E, UPC-A/EAN-13 with Extended Coupon Code, Coupon GS1 Code 32(PARAF), EAN-UCC Emulation, GS1 Data Bar Postal: Australian Post, British Post, Canadian Post, China Post, Japanese Post, Korea Post, Netherlands Post, Planet Code, Postnet
Field of view	Vertical 30°, Horizontal 40°
Ambient Light	0~100000 lux (natural light)
Voltage	3.3V
Operating Temperature	-20°C ~ + 55°C
Humidity	5% - 95% (non-considering)
Product Weight	140g
Product	96 x 64 x 37.5mm

Dimensions	
What's in the Box	1D/2D barcode reader, 2 Screws
Gift Box Weight	170g
Gift Box Dimensions	140 x 83 x 44mm

2D Diagram

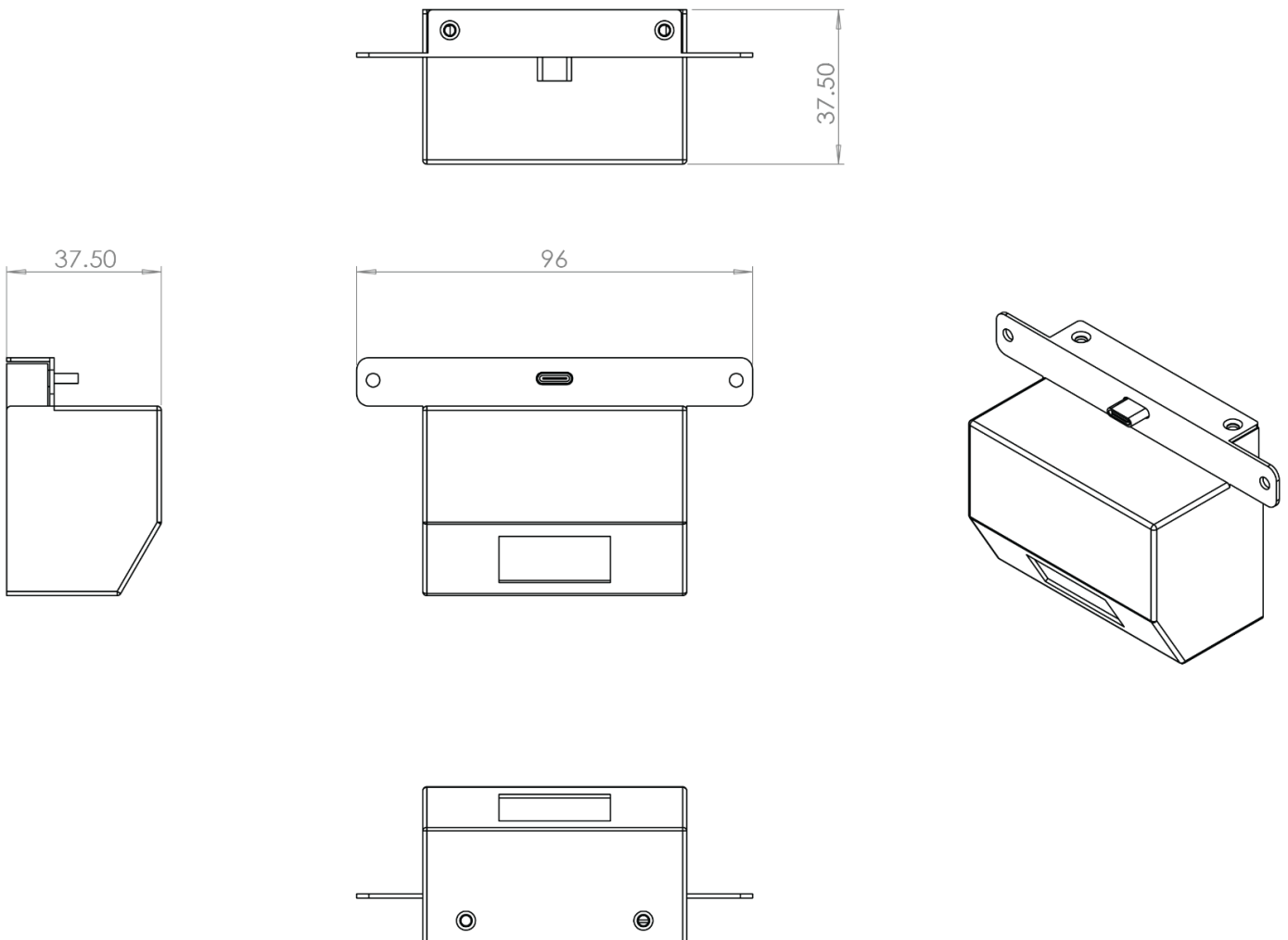

CONTACT US

United States	Hong Kong	Europe
Representative Office 1440 N. Harbor Blvd Suite 900 Fullerton, CA 92835	Flat D, 5/F, Excelsior Building, 364 Nathan Road, Kowloon, Hong Kong	Weiherstrasse 2 8564 Hattenhausen Switzerland
626 228 5927	852 23762803	44 20 3885 0392 (UK) 41 79 279 9798 (Switzerland)
sales@glorystargroup.com	sales@glorystargroup.com	sales@glorystargroup.com

To find out more about our extensive range of Glory Star solutions, go to www.glorystargroup.com, or call the office nearest you. For more information, please contact us at sales@glorystargroup.com. Glory Star reserves the right to change or update, without notice, any information contained herein; to change, without notice, the design, construction, materials, processing or specifications of any products; and to discontinue or limit production or distribution of any products. Glory Star, the Glory Star logo, STAR CONTROL and STAROS are either trademarks or registered trademarks of Glory Star Group Limited. All other trademarks are the property of their respective owners.