



GLORystAR

## 37" Capella Stretched Display



**WiFi & Bluetooth Enabled**



**Android**



**5W Speaker**

### Overview

Free Staros Kiosk Lockdown App

Star Control Remote Control Software

Commercial Grade

# Specification

	Model	CAP370 PART#568
Screen Size	Size	37"
Panel Info	Resolution	1920 x 540
	Brightness	700cd/m2
	Contrast	1000:1
	Aspect Ratio	16 : 4.5
	Active Display Area	899.712 x 253.044mm
	Viewing Angle	89°/ 89°/ 89°/ 89°
	Response Time	14ms
	Display colors	16.7M
Hardware & OS	CPU	Quad Core ARM Cortex A55@2.0GHz
	RAM	4GB DDR4
	ROM	32GB EMMC Flash
	Memory extension	TF Card extension
	OS	Android 12
Software	STAROS	License Free Kiosk Mode App and Multi App Mode, Auto Lockdown, Browser and Media Mode
	STAR CONTROL	Remote Mobile Device Management
	STARTOOL	Open Source API
	MUSEA	Digital Signage Software
Video/ Image	Video Format	MP4, MPG, VOB, MKV, MOV, FLV, AVI, 3GP, WMV,HTML5
	Audio Format	WMA, WAV, AAC, FLAC, MID, APE, MP2, 1RC M4A, MP1, etc
	Image Format	JPEG, BMP, PNG , GIF
Audio	Speaker	2 x5W
Communication	Bluetooth	BT 5.0
Connectivity	Camera	NO
	WIFI	802.11 a/b/g/n/ac 2.4GHz & 5GHz
	Ethernet	100/1000 LAN
General	Color	Metal Black Matte Paint
	I/O	RJ45x1; TFslotx1; TYPECx1 ; USB 3.0x1; USB 2.0x1; 3.5 phone jack
	External Control	IR(in/out)3.5mm jack , RS232C(in/out)2.5mm jack
	Accessories	RS232 line ; IR connection cable
	Buttons	Mute、Vol-、 Vol+ 、 Down、 UP、 Menu、 Home 、 power
	POE	NO
	Included in Box	Strip screen, Power Cable ,Remote Control
	Consumption	50W (For reference)
	Power	AC in
	Operating Environment	Working Temperature: 0-45 degree celsius
	Language	Multi language
Mounting	VESA	VESA 400 x 200mm / 200 x 200mm
Dimensions	Dimensions ( LxWXH)	914.9x280.9x48.4mm
	Weight	8.3kg
	Box size / each pc ( LxWXH)	980x132.4x357.9mm
	Master Box size ( LXWXH)	1000x294.8x387.9mm
	Master Box Weight	21.3kg
	Pieces/ Carton	2PCS

## Dimension

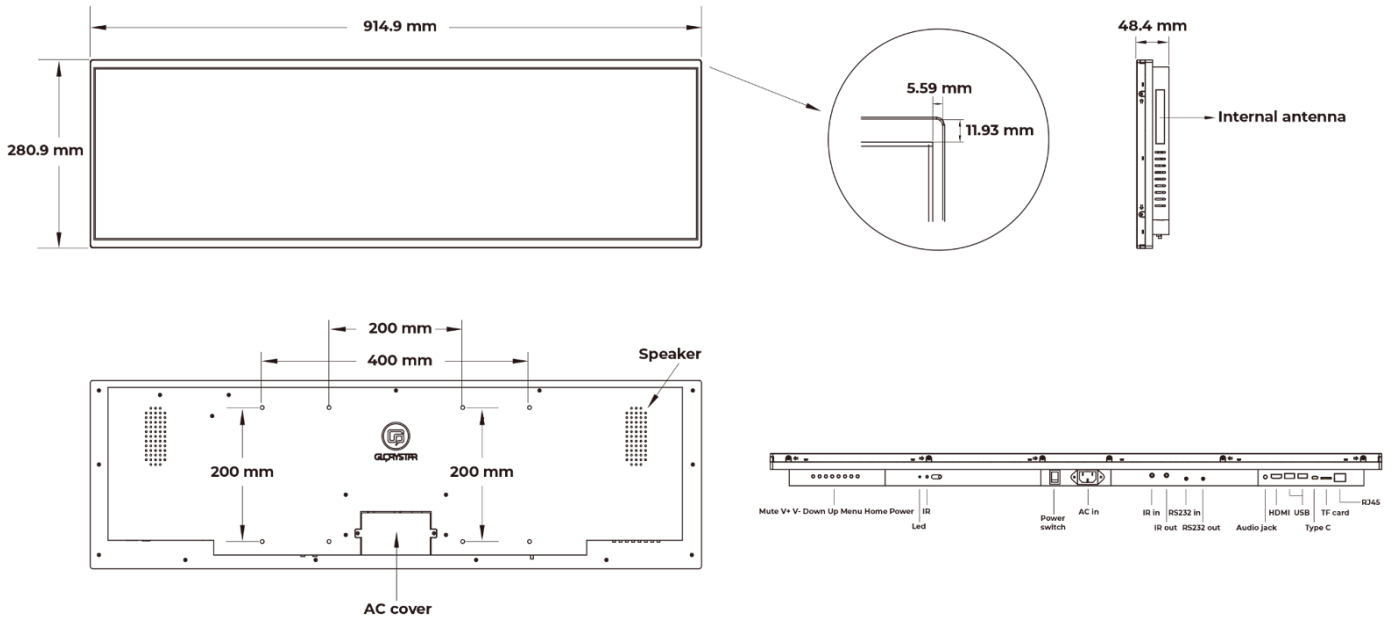

## CONTACT US

### United States

101 Hudson St., 21st Floor  
 Jersey City, NJ 07302 USA  
 626 228 5927

### Hong Kong

Flat D, 5/F, Excelsior Building,  
 364 Nathan Road,  
 Kowloon, Hong Kong  
 852 23762803

### ShenZhen

Bldg. 9, 4/F Zhong Yuntai Technology Industrial Park,  
 Tangtou No.1 Road, Shiyuan Street, Baoan,  
 ShenZhen, PRC  
 86 755 2600 1808

To find out more about our extensive range of Glor Star solutions, go to [www.glorystargroup.com](http://www.glorystargroup.com), or call the office nearest you. For more information, please contact us at [sales@glorystargroup.com](mailto:sales@glorystargroup.com). Glory Star reserves the right to change or update, without notice, any information contained herein; to change, without notice, the design, construction, materials, processing or specifications of any products; and to discontinue or limit production or distribution of any products. Glory Star, the Glory Star logo, STAR CONTROL and STAROS are either trademarks or registered trademarks of Glory StarGroup Limited. All other trademarks are the property of their respective owners.